

FM10Q

10.4" Qualcomm® Snapdragon™ 660 Android Vehicle Mounted Computer



KEY FEATURES

- Qualcomm Snapdragon™ 660 octa-core, 2.2 GHz CPU
- 10.4" 1024 x 768 Panel with PCAP touchscreen
- Field replaceable front panel to reduce service costs
- IP65 waterproof and dustproof
- Wide range -30°C to 50°C operating temperature



SPECIFICATIONS

Display			
Resolution	1024x768	Size	10.4 inches
Contrast Ratio	1200:1	Panel Brightness	400 nits 800 nits(Optional)
View Angles	88,88,88,88	Type	Projected Capacitive Multi Touch
Touch Mode	With Stylus Support With Gloves Support		
System Specification			
Processor	Qualcomm® Snapdragon™ 660 (Octa-Core 2.2 GHz)	Memory	3GB
Storage	32GB	Operating System	Android 9.0
WLAN	Support	BT	Support
WWAN	4G/LTE (Optional)	GNSS	GPS/GLONASS
Sensors	G-Sensor, Temp. Sensor		
Camera			
Front Camera	2MP Camera		
Mechanical			
Dimension	Tablet: 268 x 214 x 35 mm (10.6 x 8.42 x 1.37 inches) Docking: 202 x 245 x 52 mm (7.9 x 9.6 x 2.04 inches)	Weight	Tablet 1.7 kg (3.75 lbs) Docking 1.6 kg (3.53 lbs)
Mounting	RAM Mount/ Vesa Mount	Cooling System	Fanless Design
Housing	Magnesium Alloy Housing		
IO Ports			
USB Port	1 x USB 3.0 Type C (OTG)(Tablet) 1 x DB9 Connector for 2 x USB 2.0 Port(Docking)	Serial Port	2 x COM Port(Docking)
SD Card Slot	1 x Micro SD Card Slot(Tablet)	SIM Card Slot	1 x Dual-Nano SIM Card Slot(Tablet)
Audio	2 x Speaker(Docking) 1 x CANBus or 1 x Audio(Docking)	LAN	1 x Gigabit LAN port(Docking)
Indicator	4 x LED Indicator (Wi-Fi, BT, UPS battery, Screen Blanking, Heater)		
Environment			
Operating Humidity	5% to 95% RH, Non-Condensing	Operating	-30°C to 50°C

Storage Temperature	-30°C to 60°C	Temperature	
Vibration	MIL-STD-810G Method 514.6 Procedure I	Shock	MIL-STD-810G Method 516.6 Procedure I
Impact	Support EN62262 IK07 Rating	IP rating	IP65 Certified, Waterproof and Dustproof
		ESD	Compliant with EN 61000-4-2, Enhanced ESD to ±8kV Direct & ±15kV Air

Certification

Certification	CE, FCC
----------------------	---------

Control

Button	1 x Power Button, 6 x Function Button (Programmable Function Key Configured by Winset)
---------------	--

Power

Battery	7.6V UPS Battery (2S1P) Minimum 30 minutes	Power Rating	Docking: 10V-60V with ignition control Tablet: 12V DC In
----------------	---	---------------------	---

Security Function

SOTI MobiControl	SOTI MobiControl Compliance
-------------------------	-----------------------------

Accessory

Accessory	5M Power Cable with Fuse Kit 0.3M USB Cable 0.15M Power Converter Cable DC Jack Power Cable 84W Adapter with power cable Cable Clamp Kit Wi-Fi Antenna x 2 Quick Start Guide External Antenna Fixing Bracket Dock + Latch Locking Key Stylus Kit + Screw	Optional Accessory	1.8M RS232 Cable 0.3M Audio Cable 1.8M CAN BUS Cable 1.8M CAN BUS Open Wire Cable 2M IP65 LAN Cable GPS & LTE 2M Combo Antenna (VM240) GPS & LTE 5M Combo Antenna (VM9C) Magnetic Combo Antenna (VM10S) WWN Antenna HDMI Adapter
------------------	--	---------------------------	---

DIMENSIONS UNIT:MM

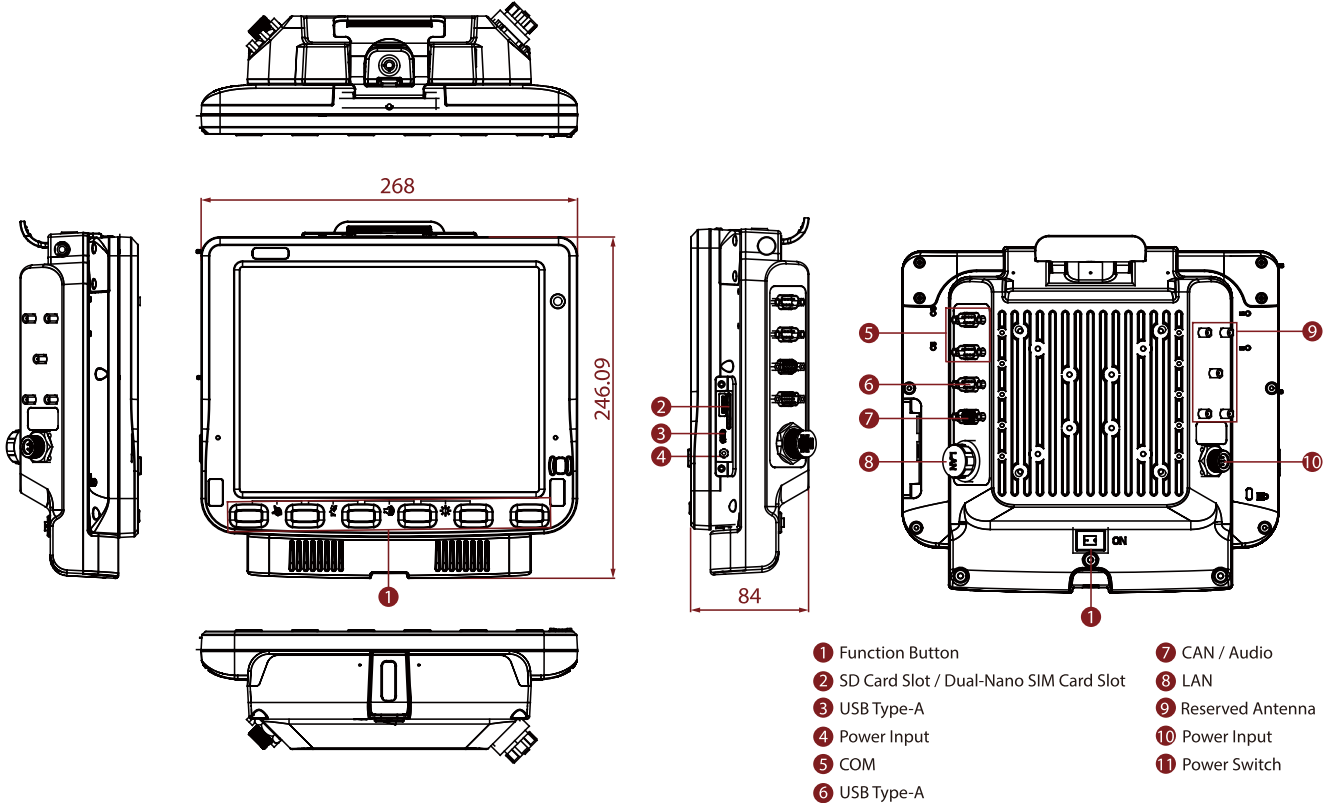

NOTE

1. Total usable memory will be less dependent upon actual system configuration.
2. CANBus and audio are mutually exclusive.
3. The heater is a customized feature available by request.
4. SOTI is available upon request.
5. Length measurements do not include protrusions. Weight varies with options.
6. Measured at dimming LCD brightness. Varies depending on the usage conditions, or when an external device is attached.
7. Accessories may vary depending on your configuration.
8. Two Wi-Fi antennas are included in the standard package.
9. The product shown in this datasheet is a standard model. For diagrams that contain customized or optional I/O, please contact the Winmate Sales Team for more information.
10. Please order one bracket for one antenna. For example, if you plan to use two antennas, please order two brackets.
11. Notice that only one antenna is included in the package. If you plan to use the WWAN function please order two WWAN antennas.
12. This is a simplified drawing and some components are not marked in detail.